

Zonecheck®

450 with key-switch

ZC450-IB-12/21-06-US

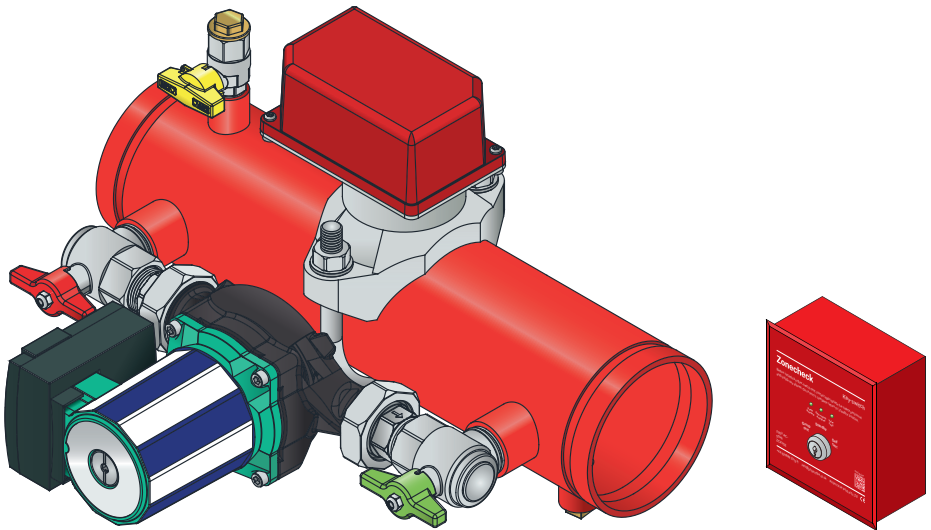

*

Instruction Booklet

Copyright

This instruction booklet is property of Project Fire Products Ltd and must not be used or copied without its written permission.

Information

While every effort has been made to ensure that the information contained within this document is correct, Project Fire makes no guarantee for completeness or accuracy. Project Fire Products Ltd reserves the right to change product specifications, designs and standard equipment without notice and without incurring obligation.

Zonecheck is a registered product name of Project Fire Products Ltd. European patent No. 0907833.

Contents

- 1 Pre-checks
- 2 Installation
- 3 Commissioning
- 4 Testing
- 5 Orientation
- 6 Typical connection
- 7 Stand Alone Test Wiring
- 8 Group Test Wiring
- 9 Flow-switch Wiring
- 10 Dimensions
- 11 Specifications
- 12 Troubleshooting
- 13 Important Information
- 14 Approvals
- 15 Warranty & End of Life Cycle

Pre-checks

Before you install Zonecheck follow these simple steps.

- 1 Open the box and remove all packaging.
- 2 Check you have the correct size manifold.
- 3 Check that you have the correct model for your site (right or left handed).
- 4 Check that there is a key-switch and key in the box.
- 5 Inspect the product to make sure it hasn't been tampered with. If you have any queries please contact your supplier.

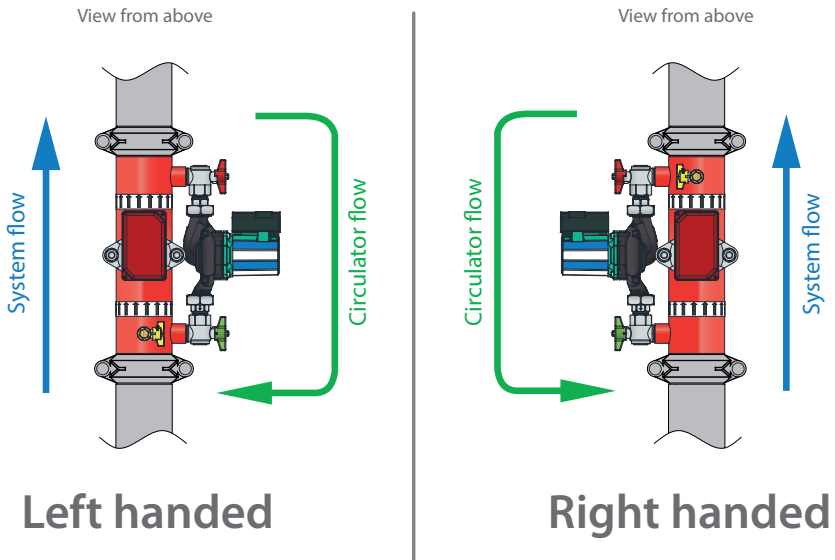

Installation

Zonecheck should be installed by a competent fire sprinkler installer and wired up by a qualified electrician.

- 1 Contact building management to inform them of the proposed works.
- 2 Isolate and drain down selected zone.
- 3 Orientate the Zonecheck in accordance with the diagrams in this booklet.
- 4 Install the Zonecheck with two approved grooved couplings (not supplied).
- 5 Double check that the sprinkler flow arrows on Zonecheck are facing the correct direction (see diagrams included in this booklet).
- 6 Fit the key-switch to the wall in a suitable location that is easy to reach from floor level.
- 7 Wire the Zonecheck pump and flow-switch to the key-switch in accordance with the diagrams in this booklet.
- 8 Wire the flow-switch to the appropriate fire-detection panel in accordance with the diagrams in this booklet.
- 9 If required, wire monitoring cables from zone valve to key-switch.
- 10 Wire the appropriate power supply to the key-switch.
- 11 Proceed to Commissioning instructions.

**DO NOT ATTEMPT TO RECONFIGURE.
TAMPERING WILL VOID THE WARRANTY!**

Commissioning

- 1 Contact the responsible person to authorise a flow-switch test.
- 2 Ensure the Zonecheck red and green valves are both open.
- 3 Now remove access plug (air vent) on the end of the Zonecheck pump .
- 4 Using an appropriate screwdriver turn the shaft clockwise and anti-clockwise to check the free movement of the shaft and impeller (see fig 2), replace the access plug.
- 5 Attach a barrel nipple and hosepipe to yellow vent valve on the Zonecheck.
- 6 Turn the key-switch to SELF TEST.
- 7 Carefully open the vent valve on the Zonecheck unit until only water is being expelled (this can take up to 10 minutes).
- 8 Turn the key-switch to STANDBY.
- 9 Close vent valve, remove the barrel nipple and hose and replace plug.
- 10 Now connect the barrel nipple and hose pipe to the test valve at the furthest point on the zone or use the test/drain valve provided on the Zonecheck unit.
- 11 Discharge water through the hose (this is a once only commissioning test).
- 12 Wait for the FLOW-SWITCH ACTIVATED to illuminate on the key-switch (this could take up to 30 seconds).
- 13 Close the test/drain valve.
- 14 Turn the Zonecheck Key-switch to SELF TEST and check the PUMP RUNNING and FLOW-SWITCH ACTIVATED LEDs are illuminated (this could take up to 30 seconds).
- 15 Confirm with the responsible person that they have received their test signal.
- 16 Turn the Key-switch key to STANDBY.
- 17 If zone valve is wired to key-switch, check function of VALVE FAULT LED on the key-switch, which should illuminate when valve is not in the fully open position.
- 18 Ensure that the end user is instructed on how to carry out a routine test and explain procedure for when VALVE FAULT LED is illuminated (if connected).
- 19 Fix operating instructions to wall, preferably next to the key-switch. Also place the Zonecheck Isolation valve location sticker in a suitable position to let others know where the unit is.
- 20 Fill in & hand over a completion certificate. Make sure that the responsible person has been made aware that the system is back online.

Fig 1

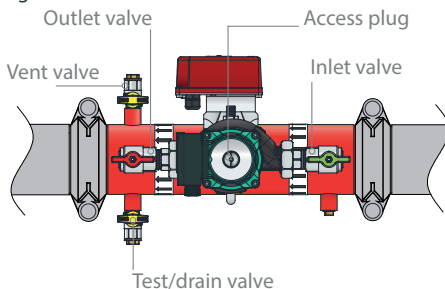
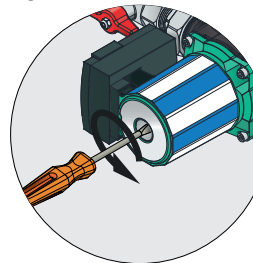

Fig 2



Testing

Test one Zonecheck

- 1 Insert the key into the key-switch and turn to SELF TEST (the pump light will activate).
- 2 When the flow-switch operates, the FLOW-SWITCH ACTIVATED light will illuminate (please wait for up to 30 seconds for the flow-switch to operate).
- 3 Return to STANDBY position and remove the key.

Test a group of Zonechecks

- 1 To test all the Zonechecks in the group, insert the key into the key-switch and turn to GROUP TEST.
- 2 Look at the central fire control panel to confirm simultaneous activation of all the flow-switches within the group.
- 3 Return to STANDBY position and remove the key.

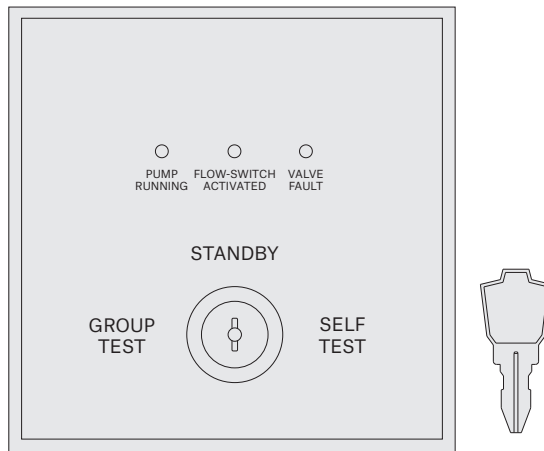

Orientation

- The pump direction-of-flow arrow faces the opposite direction to the system flow.
- The red & green stripes on the pump cartridge are always horizontal.
- Do not position the flow-switch on the underside of the pipe.
- For vertical flow applications, only mount flow-switch where up-flow conditions exist.

Side view

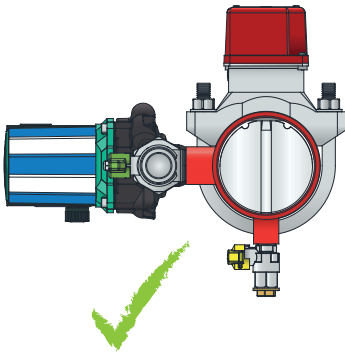

Plan view

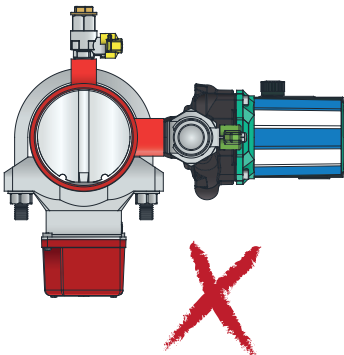
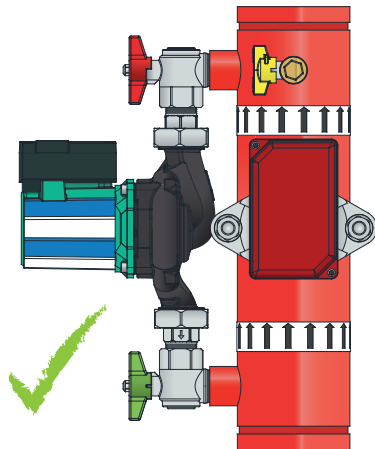

Flow-switch on underside of pipe

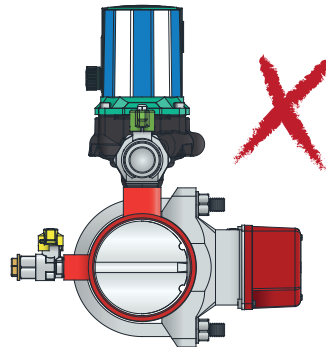

Pump not horizontal

Typical Connection

A typical multi-occupancy Zonecheck Installation. For an example of a typical riser installation visit our website at www.projectfire.co.uk.

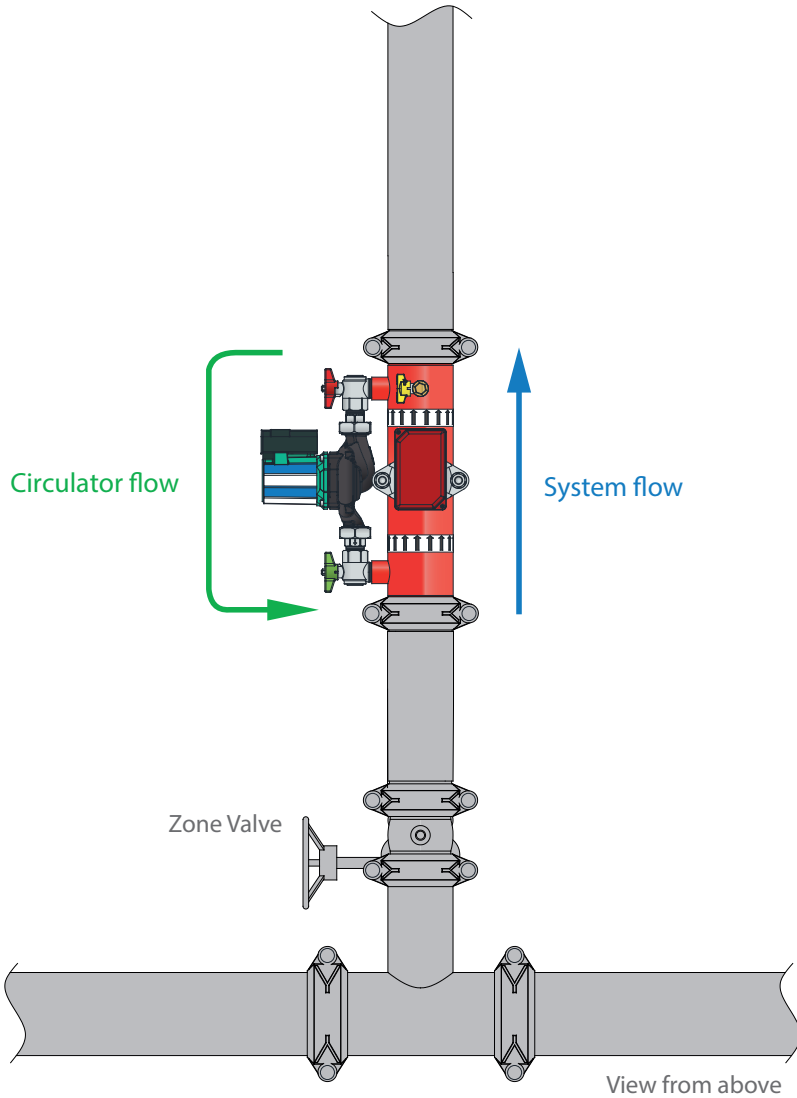

Stand Alone Test Wiring

Please note Zonecheck should be installed by a competent fire sprinkler installer and wired up by a qualified electrician.

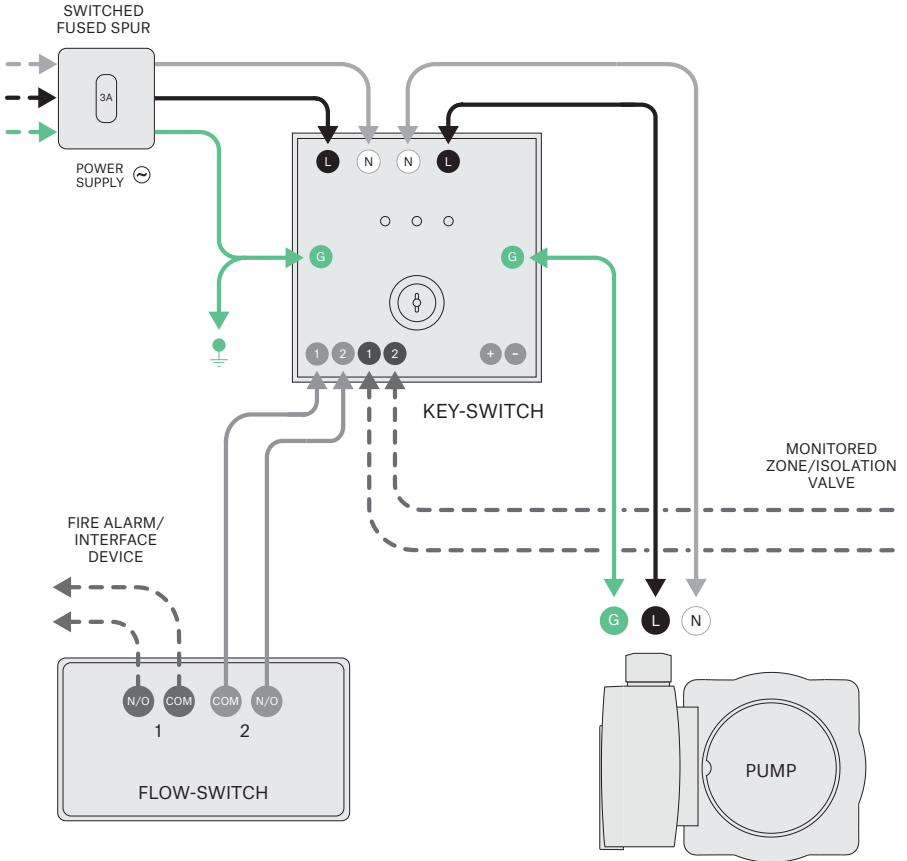

Group Test Wiring

Upto 25 Zonechecks can be tested simultaneously when the Zonecheck units are wired in parallel via interconnect by turning the master key-switch to GROUP TEST. The maximum cable distance of 300m should not be exceeded when grouping key-switches.

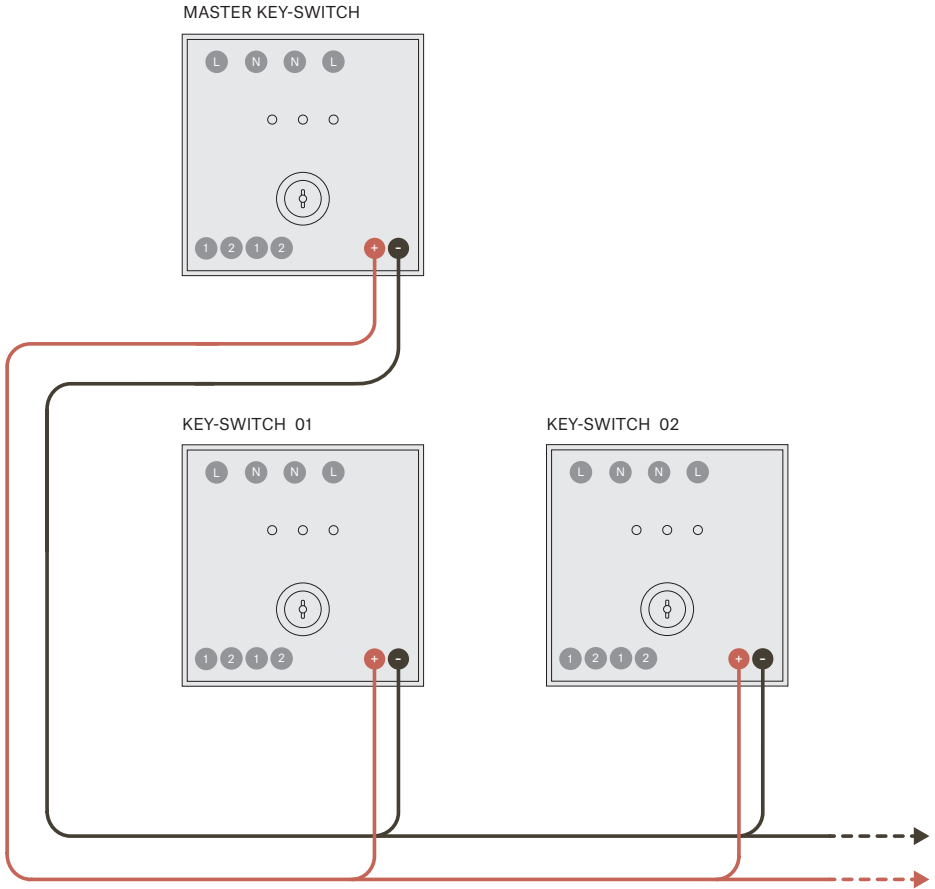

Flow-switch Wiring (Typical)

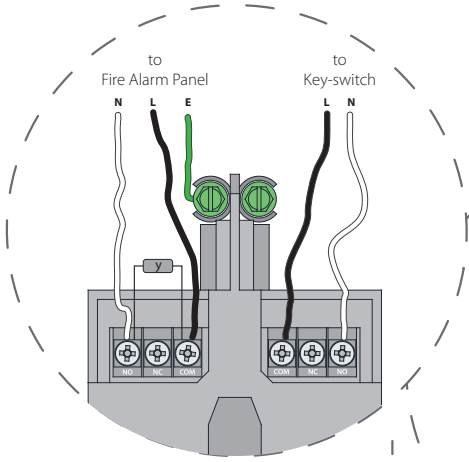

TYPICAL 1

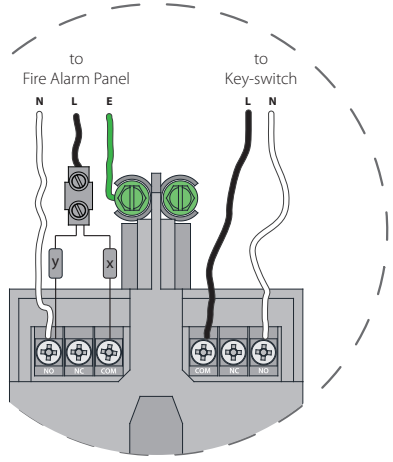

TYPICAL 2

Typical fire-alarm/ flow-switch connections. Exact wiring required depends on type of fire panel used. Refer to specific fire-alarm panel instructions for more information/guidance.

Resistors sized according to specific alarm-panel requirements.

x = fire alarm resistor (usually 1Ω)
 y = end of line resistor (usually 470Ω)

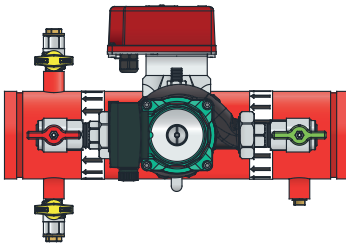

Dimensions

Please check your version of flow-switch (System Sensor or Potter) before referring to dimensions.

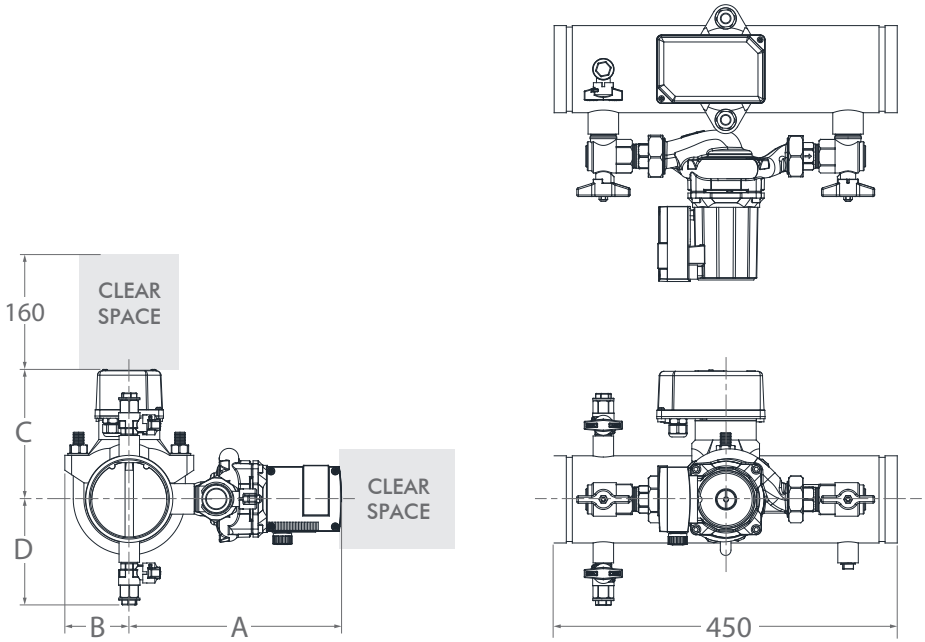

Ømm (in)	A mm (in)	B mm (in)	C mm (in)	D mm (in)
50 (2")	256 (10")	58 (2.3")	145 (5.7")	116 (4.6")
65 (2½")	264 (10.4)	58 (2.3)	155 (6.1)	124 (4.9)
80 (3")	271 (10.7")	66 (2.6")	165 (6.5")	130 (5.1")
100 (4")	283 (11.1")	86 (3.4")	170 (6.7")	140 (5.5")
150 (6")	309 (12.2")	113 (4.5")	200 (7.9")	168 (6.6")
200 (8")	336 (13.2")	148 (5.8")	235 (9.3")	195 (7.7")

Specifications

Zonecheck 450

Working Pressure Rating.....	Water, 12 bar (175 psi) maximum
Operating Temperature Range.....	0°C - 49°C (32°F – 120°F)
Pipe Diameter.....	50, 65, 80, 100, 150 & 200 mm (2, 2½, 3, 4, 6 & 8")
Approvals.....	LPCB, UL, FM and VdS

Circulation Pump

Type.....	Wilo Top-S
Operating Voltage.....	120vac, 60Hz
Full Load Current.....	1.63 A
Power Rating.....	195 W maximum
IP Rating.....	IP44
WP Rating.....	12 bar (175 psi)

Flow-switch

Type.....	Potter VSR-EU
Contact Rating.....	10Amps @ 125/250 VAC; 2.0Amps @ 30 VDC resistive; 10mAmps min. @ 24 VDC
IP Rating.....	IP54
Triggering Flow Rate.....	15-38LPM (4-10 GPM)
Maximum Surge.....	5.5 m/s (18 FPS)
Time Delay.....	0 - 30 s

Key-switch

Type.....	ZCKYSU
Operating Voltage.....	120v, 60 Hz
Internal Consumption.....	7.5 W Maximum
Operation Modes.....	Self-test: Wired locally Group test: Interconnected
Standby (Ready state).....	No LED
Test Initiation.....	'Pump Running' LED
Flow Switch Activation.....	'Flow-switch Activated' LED
Valve Fault (optional).....	'Valve Fault' LED

Troubleshooting

Zonecheck should be troubleshooted by a competent fire sprinkler installer and wiring checked by a qualified electrician.

No lights on key-switch.	Open the key-switch and check the wiring against the wiring diagram. Confirm the power supply has been connected properly.
Only pump light on.	<ol style="list-style-type: none">1 Check the red & green Zonecheck valves are open.2 Check Zonecheck has been installed facing the correct way.3 Remove the plastic lid from the flow-switch, push and hold the trigger with your finger for 30 seconds. If the water-flow light (on the key-switch) operates see below. If not check the wiring against the diagram.
Pump runs hot and does not operate the flow-switch.	<ol style="list-style-type: none">1 Attach hosepipe to yellow vent valve on the Zonecheck.2 Carefully open the vent valve on the Zonecheck unit to remove the air, allow water to drain to make sure all air is bled from the unit.3 Close vent valve and replace plug.4 Close the red valve and the green valve on Zonecheck.5 Remove the access plug (air vent) and vent the circulator until water drains from the vent.6 Insert a flat headed screwdriver and rotate the propeller shaft several times by turning the screwdriver. Replace the access plug ensuring the 'O' ring's seal is maintained.7 Open the red valve and the green valve on Zonecheck.

Important Information

- Ensure Zonecheck is installed both mechanically and electrically commissioned and tested prior to leaving site.
- Ensure protection to Zonecheck is employed whenever there is an extended period from installation to commissioning.
- If the Zonecheck could be wired when the sprinkler system zone is drained down then it is vitally important that the Zonecheck red and green valves are left in the closed position, to ensure the motor is not accidentally run dry and damaged. (Please ensure the commissioning engineer is aware of the closed Zonecheck valve status).
- Always use a flat faced wrench for Zonecheck commissioning.
- The suggested location for the key-switch is at low level, adjacent to the fire alarm panel.
- Fix operating instruction to wall, preferably next to key-switch.
- Each Zonecheck is factory assembled and tested. Do not attempt to reconfigure. Tampering will void the warranty.
- Maximum working pressure - 12 bar (175 psi), test pressure - 18 bar (260 psi).
- Use Zonecheck flow-switch testers in wet-pipe systems only. Do not use in dry pipe, deluge, or pre-action systems.
- Only activate the Zonecheck key-switch when the valves are opened and the sprinkler system is full.
- The 'Standby' mode will not give any false alarms when fitted in conjunction with an approved water-flow alarm device.

Standards & Approvals

In the majority of multi-occupancy sprinklered premises it is a requirement of BS EN 12845 that each tenant should carry out a functional test on a fitted flow-switch every quarter. All international fire code standards such as NFPA etc all make the flow-switch test mandatory. Zonecheck can carry out this test by simply initiating a key-switch. Only equipment currently approved by the Loss Prevention Certification Board (LPCB), Underwriters Laboratories (UL), Factory Mutual (FM) and VdS is used as a part of Zonecheck.

Zonecheck simplifies testing by re-circulating the water within the pipe around the flow-switch to simulate the flow of one sprinkler head in operation, regardless of where the Zonecheck is installed or located in the system. As water operates the flow-switch paddle and electronic signal is sent back to the key-switch to indicate that the flow-switch has operated correctly. Throughout the whole process water is being re-circulated within the system and no water is discharged as Zonecheck is a closed loop system.

One Year Warranty

Project Fire Products warrants its enclosed Zonecheck flow-switch tester to be free from defects in materials and workmanship under normal use and service for a period of one year from date of manufacture. Project Fire Products makes no other express warranty for this flow-switch tester. No agent, representative, dealer or employee of the Company has the authority to increase or alter the obligations or limitations of this warranty. The Company's obligation of this warranty shall be limited to the repair or replacement of any part of the flow switch tester, which is found to be defective in materials or workmanship under normal use and service during the one-year period commencing with the date of manufacture. After phoning Project Fire's number, 01889 271 271 for a Return Authorization number, send defective units postage prepaid to Project Fire, Pasturefields Industrial Estate, Pasturefields Lane, Hixon, Staffs, ST18 0PH. Please include a note describing the malfunction and suspected cause of failure. The Company shall not be obligated to repair or replace units, which are found to be defective because of damage, unreasonable use, modifications, or alterations occurring after the date of manufacture. In no case shall the Company be liable for any consequential or incidental damages for breach of this or any other Warranty, expressed or implied whatsoever, even if the loss or damage is caused by the Company's negligence or fault.

End of Life Cycle

Project Fire recommend that at the end of the products life cycle the items need to be disposed of correctly:

Disposal of business or commercial waste should be in compliance and accordance with government guidance and regulations.

Disposal of electrical waste should be in compliance and accordance with "Waste Electrical and Electronic Equipment recycling"

projectfire

innovators in fire protection

Project Fire Products Ltd
Pasturefields Lane
Hixon, Staffordshire
ST18 0PH, UK

+44 (0)1889 271271
support@projectfire.co.uk
www.projectfire.co.uk