

Residential Sprinkler System Testing & Monitoring

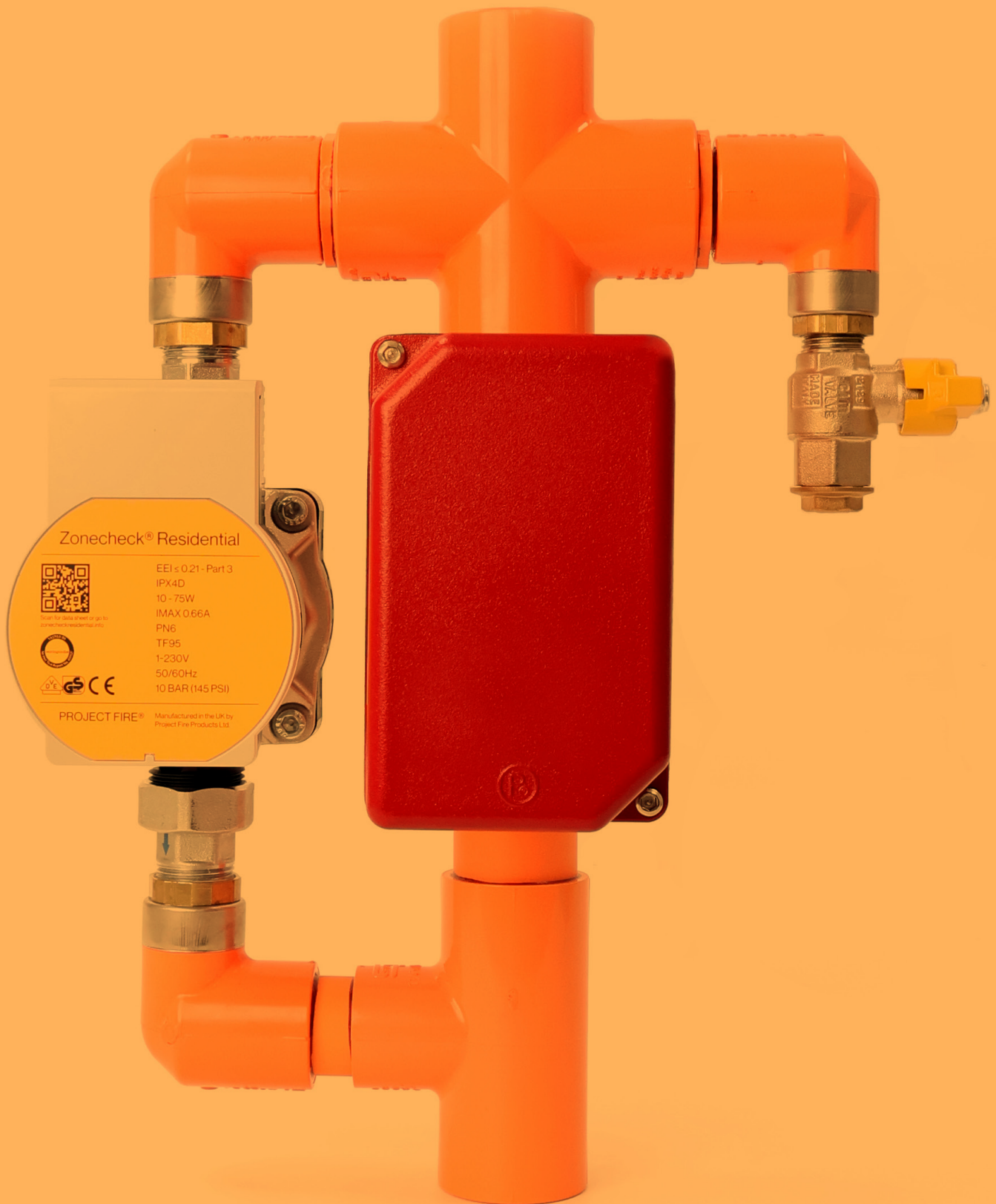

Zonecheck® Residential

A discreet, compact unit designed to offer easy installation into smaller residential risers and voids.

Testing and monitoring with no disruption to tenants.

Zonecheck is simply the easiest way to carry out flow-switch testing. It has been installed in commercial buildings world-wide, providing an easy and efficient way of maintaining code compliance. As we move to a more stringent and sustainable approach to our homes, our residential products aim to offer a cost-effective, simple sprinkler testing solution for multi-storey residential properties.

SPRINKLER TESTING FOR THE HOME

Sprinkler systems save lives as well as property, however, they do require regular testing to ensure correct operation in the event of a fire. Traditionally, water discharged from the systems to a local drain for every flow-switch. Zonecheck can perform this test quickly and efficiently without wasting a drop of water.

Our solution enables the end-user to be able to efficiently test each flow-switch without the need to discharge water from the system, or even inform occupants that there is any maintenance work being carried out. A compliant test can be carried out at the flick of switch (or fully automated as a part of our addressable system).

RESIDENTIAL SPRINKLER ZONE PACKAGES

With the addition of a local monitored valve we now offer residential zone equipment packages designed to meet BS 9251. The packages consist of Zonecheck Residential and a residential monitored valve supplied with either a key-switch or IMM depending on the application.

DESIGNED SPECIFICALLY FOR THE RESIDENTIAL MARKET TO OFFER A LOW COST SOLUTION THAT IS EASILY INSTALLED INTO SMALLER RESIDENTIAL RISERS AND VOIDS.

ZONECHECK RESIDENTIAL

The Zonecheck system is the sustainable way to carry out this important test quickly and efficiently. Zonecheck simplifies testing by re-circulating the water within the pipe around the flow-switch (no water is discharged from the system) simulating the flow of one sprinkler head in operation. The residential model has been designed as a compact solution that can be easily installed in tight spaces within residential buildings.

Zonecheck is easy to use and requires no specialist skills - a test is activated at the turn of a key or automated via our addressable system. Zonecheck Residential is supplied with a mini-switch as standard for basic testing functionality or a key-switch for additional monitored valve inputs and LED feedback.

OUR SOLUTION ENABLES THE END-USER TO EFFICIENTLY TEST EACH FLOW-SWITCH WITHOUT THE NEED TO DRAIN WATER, OR EVEN INFORM OCCUPANTS THAT THERE IS ANY MAINTENANCE WORK BEING CARRIED OUT.

System Benefits

CAPEX SAVINGS

Keep operational costs down with Zonecheck's efficient method of routine testing and reduced facilities management.

RESI ZONE PACKAGES

Residential Monitored Valves can be added to Zonecheck orders, an easy solution for complete zone equipment packages.

ZERO DISRUPTION

Flow-switch testing can be carried out by building maintenance services with no disruption for tenants.

BESPOKE DESIGN

Designed specifically for easy installation into smaller residential risers and voids.

NO WATER DISCHARGE

There is no water discharged from the system during flow-switch testing when using Zonecheck.

SIMPLE TESTING

Carry out testing with a turn of a key or fully automated via our addressable system.

INTEGRATED TECHNOLOGY

Zonecheck can be integrated into a building's fire alarm system or BMS*.

Drain/test valve (available as 15mm or full bore with pressure gauge).

Circulating pump.

Flow-switch.

CPVC pipe.

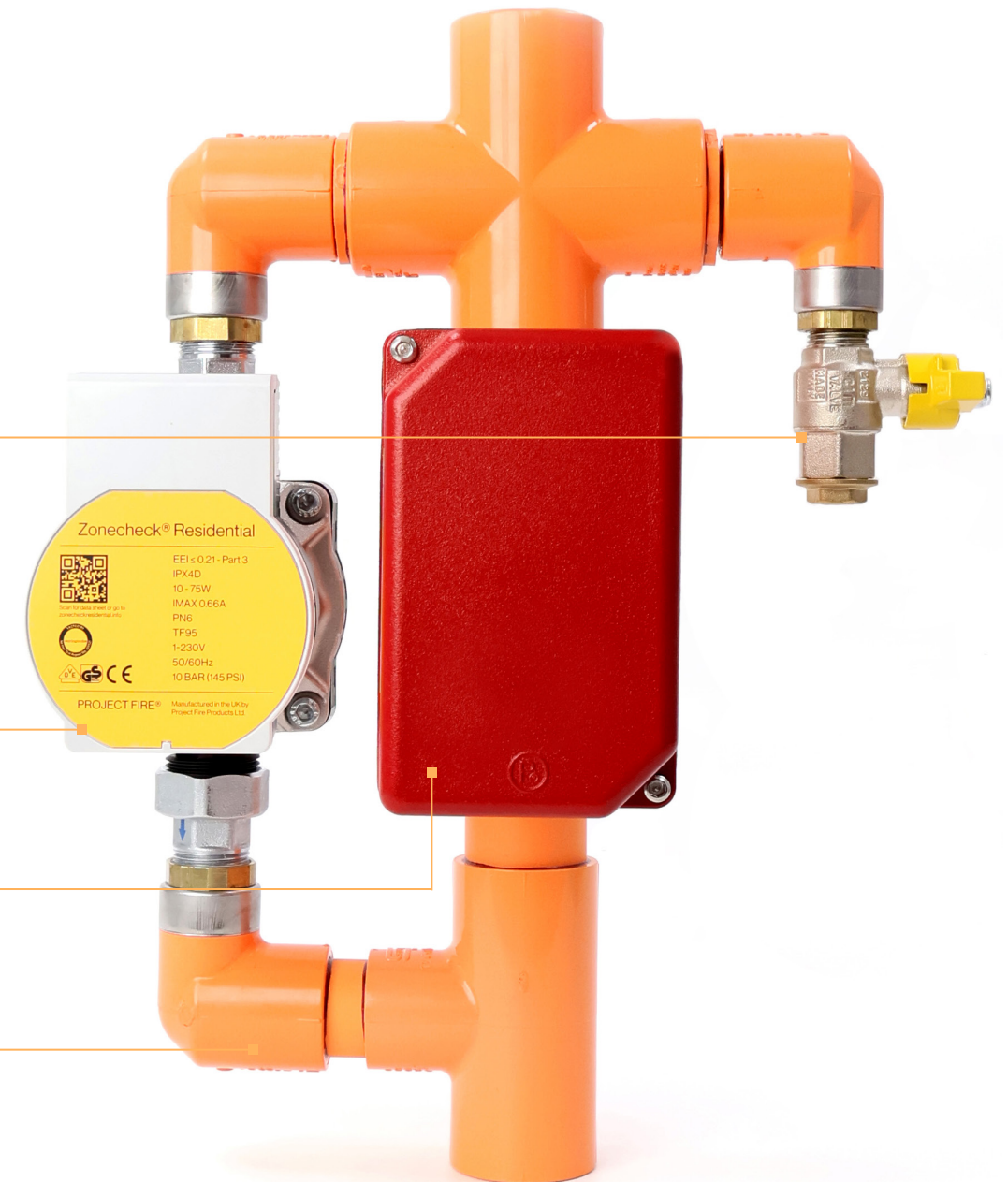

(Riser model shown, full bore drain models with pressure gauge also available)

CODE COMPLIANCE & TESTING

Zonecheck Residential enables easy compliance with applicable maintenance requirements detailed in BS 9251. Tested by WarringtonFire, Ad-Hoc Test Report No. 409529.



**The Warringtonfire Logo appearing above right is used by Project Fire Products Limited in the United Kingdom under licence from Warringtonfire and is evidence that 'Zonecheck Residential' a CPVC (Chlorinated polyvinyl chloride) flow-switch detector tester has been tested in England on February 5th 2019.*

Product Configurations

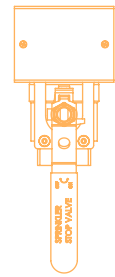
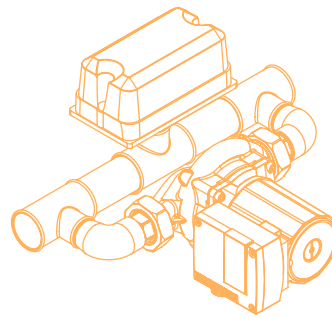
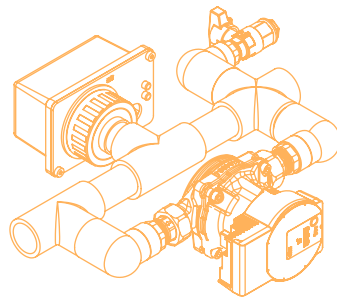
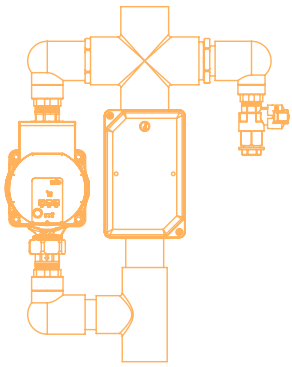

RISER	VOID	GALVANISED	MONITORED VALVE
25 - 50MM	25 - 50MM	25 - 40MM	25 - 65MM
15mm or full bore drain valve.	15mm or full bore drain valve.	LPCB approved.	An additional monitored valve can be supplied every Zonecheck Residential unit or separate as required.
Mini-switch, Key-switch or IMM*	Mini-switch, Key-switch or IMM*	Mini-switch, Key-switch or IMM*	
Designed with a narrow footprint specially for riser applications.	Designed with flat specially for riser applications.	Designed for standard steel piping installations.	

*Can be supplied with either a mini-switch/key-switch for standalone applications or an IMM for fully automated testing (see Zonecheck Addressable).

TOGETHER WE CAN HELP MAKE
RESIDENTIAL BUILDINGS SAFER, FOR
MORE INFORMATION GET IN TOUCH
WITH A MEMBER OF OUR TEAM.

Designed and manufactured in the UK by Project Fire Products Ltd.

+44(0)1889 271271
info@projectfire.co.uk
www.projectfire.co.uk
www.zonecheckresidential.info

Zonecheck® is a registered trademark.
© Project Fire Products Ltd. 2022. Addressable system patent no. GB1606263.0.